

UNIFIX 800 EGF

FR

EN

ES



Le support multi panneaux

Multi solar panels mounting bracket

El soporte para paneles solares múltiples

Cher client, nous vous remercions pour votre achat de l'un de nos produits Uniteck. Veuillez lire avec attention toutes les instructions avant d'utiliser le produit.

DESCRIPTION

Le support Unifix 800 EGF a été conçu spécialement pour fixer vos panneaux photovoltaïques Unisun ou équivalents (cf partie panneaux compatibles).

Simple à installer, Unifix 800 EGF s'utilise sur une surface plane rigide à l'horizontale (ex: pelouse, sable, sol béton, ossature bois).

Il peut être soit :

- fixé à un sol de type béton grâce à 8 goujons M8 (non fournis)
- lesté en utilisant la caisse de lestage pour UNIFIX 800 EGF (option)
- lesté en utilisant le support pour dalles béton (option)

Grâce à sa structure en acier galvanisé et sa visserie adaptée résistant à la corrosion, il est parfaitement adapté pour un usage en extérieur.

Doté du système d'inclinaison multi-positions, le support Unifix vous permet d'optimiser vos performances en fonction de l'orientation choisie :

- seul : l'angle de réglage est de 10 à 60 degrés
- avec option boîte de lestage : l'angle de réglage est de 30 à 60 degrés
- avec le support dalle béton : l'angle de réglage est de 20 à 60 degrés

Grâce à sa conception innovante, le support UNIFIX 800 EGF peut être utilisé pour réaliser une installation multi-panneaux.



PANNEAUX COMPATIBLES

Grâce à son design basé sur l'utilisation de perçage Oblong, Unifix permet la fixation de différents panneaux du marché avec fixation par vis M8.

Unifix 800 EGF accepte des panneaux de dimensions :

- largeur de 808 à 1100 mm
- longueur de 1200 à 1800 mm

LESTAGE PAR CAISSE A REMPLIR OU AVEC DALLE BETON (OPTION)

Le lestage doit être adapté à l'environnement d'utilisation (pays, zone de vent, ...) et de l'inclinaison. UNITECK ne pourra être tenu responsable d'un lestage non adapté.

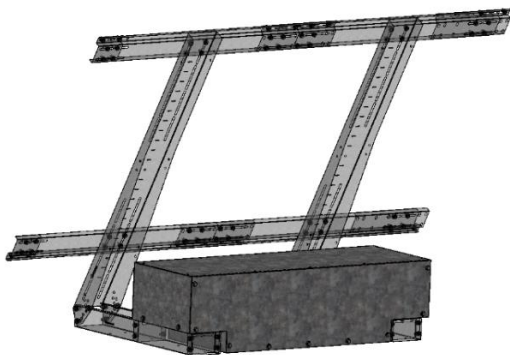

La caisse de lestage UNITECK est prévue pour le support UNIFIX 800 EGF et pour le lestage de 2 panneaux dont l'angle d'inclinaison est de 30 à 60 degrés. Elle possède une capacité de 130 litres soit 0,13 m³.

La caisse de lestage est prévue pour contenir du sable sec de densité 1800 Kg/m³ soit un total de 240 Kg.

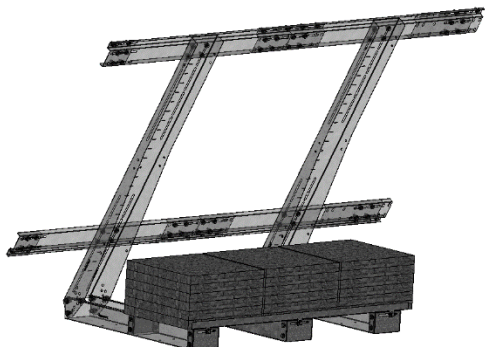

Le support Dalle Béton UNITECK est prévu pour supporter des dalles béton de 40 cm x 40 cm.

Le support dalle béton UNITECK peut supporter jusqu'à 24 dalles standards d'un poids de 12,5Kg soit un poids total de lestage de 300 Kg.

L'angle d'inclinaison peut varier de 20 à 60 degrés selon le nombre de dalles utilisées.

RECOMMANDATIONS

- Montez le support Unifix uniquement sur des surfaces présentant une portance suffisante. Tenez compte de la charge supplémentaire avec panneau :

Support	Panneau
Unifix 800 EGF = 23 kg	2 x Unisun 300.12M = 2 x 18 kg

- Pour éviter que de grandes quantités de neige ne s'accumulent derrière le capteur, installez en amont des grilles d'arrêt appropriées.
- La disposition des capteurs influence vos performances électriques. Choisissez l'inclinaison et l'orientation la plus optimale en fonction de votre environnement. Évitez les zones d'ombre ou que certains objets ne soient source d'ombre (ex. arbre)

CONSIGNES DE SÉCURITÉ

- Prenez les mesures appropriées pour prévenir les accidents pendant vos travaux de montage.
- Si le support et le matériel de montage sont exposés aux rayons du soleil pendant une longue période, il y a un risque de brûlure. Protégez-vous.
- À la fin des travaux, vérifiez que vos supports et panneaux soient bien fixés



MONTAGE SUPPORT UNFIX 800 EGF

Couple de serrage préconisé

Nb. Coefficient de frottement moyen $\mu=0,20$ / Serrage à 50% de la limite élastique

Vis	Couple
M 8	21,50 Nm
M 10	44,00 Nm

- Réalisez le montage des pieds.

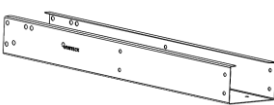
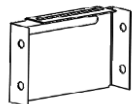
	M8x20 X16
	D8 X16
	M8 X16
	N°169 X2
	N°181 X4



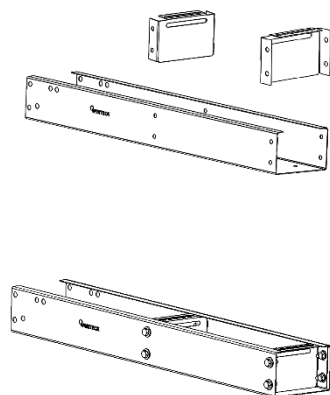

Pour utilisation avec caisse de lestage

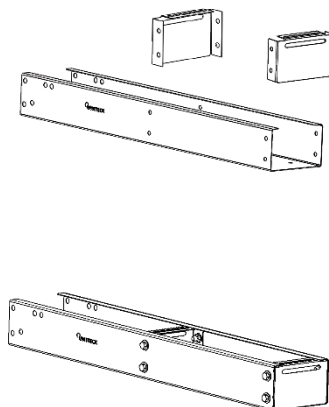

Pour utilisation autre





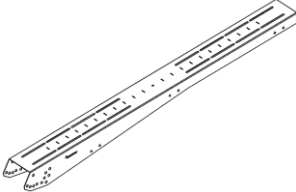

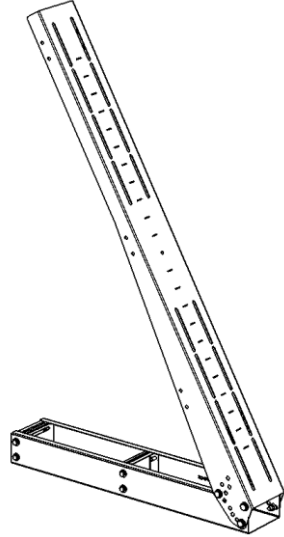
MONTAGE SUPPORT UNIFIX 800 EGF (SUITE)

	M10x25 X12
	D10 X12
	M10 X12
	X2
	N°168 X2

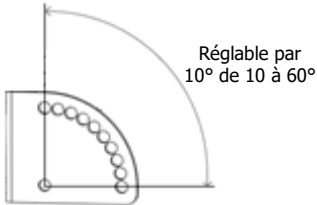



- UNIFIX dispose d'un système d'inclinaison multi-positions. Définissez l'inclinaison souhaitée en fonction de l'orientation choisie.



Performance électrique en fonction de l'inclinaison et de l'orientation panneau				
	0° 	30° 	60° 	90° 
Est	93%	90%	78%	55%
Sud-Est	93%	96%	88%	66%
Sud	93%	100%	91%	68%
Sud Ouest	93%	96%	88%	66%
Ouest	93%	90%	78%	55%

MONTAGE SUPPORT UNFIX 800 EGF (SUITE)

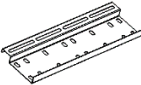
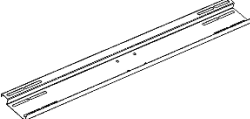

- Prenez les pièces N°170 et 171, positionnez-les puis réalisez un pré-serrage des vis. La fixation totale se fera ultérieurement.

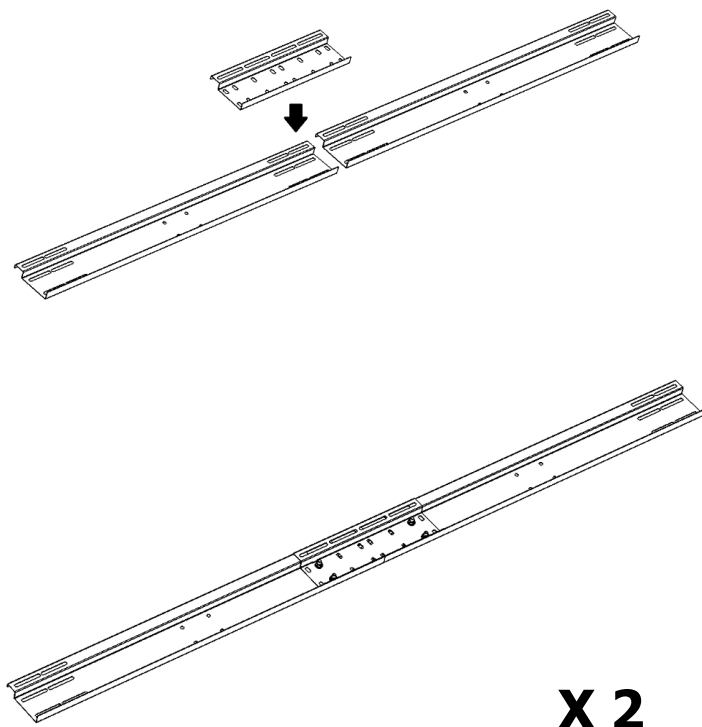
				
M8 X8	D8 X8	M8 X8	N°170 X2	N°174 X4



MONTAGE SUPPORT UNIFIX 800 EGF (SUITE)

- Fixez les traverses préalablement préparées sur les pieds. Ne les serrez pas totalement.

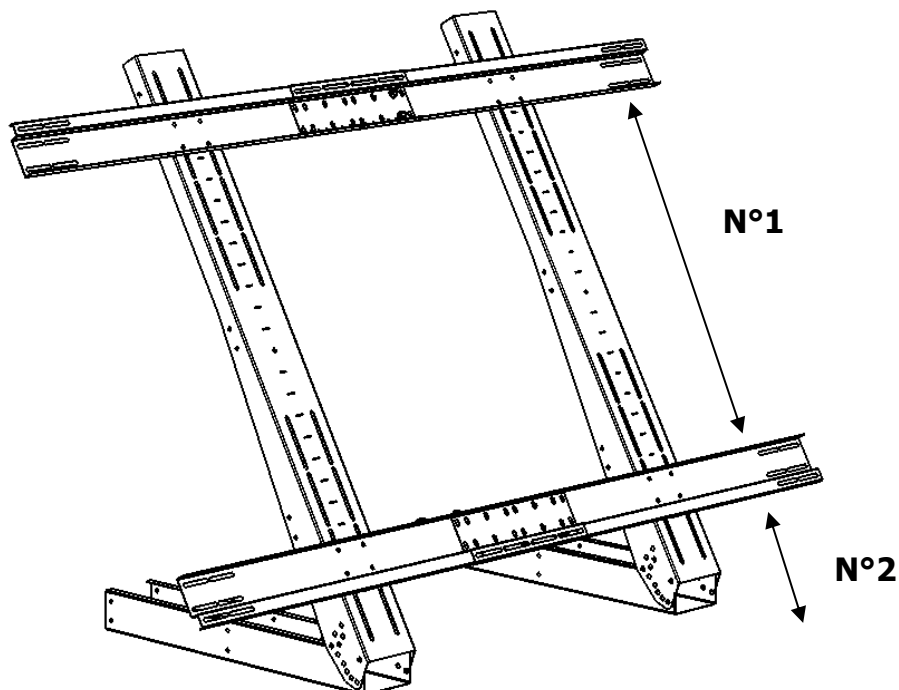

		
M8 X16	D8 X16	M8 X16

- Le support UNIFIX 800 EGF est adaptable sur tous types de panneaux.
- Pour réaliser un pré réglage, mesurez les entraxes de fixation de votre panneau afin de pré régler la distance **N°1**.
- Si vous utilisez votre support UNIFIX 800 EGF dans un pré, une pelouse, la distance **N°2** doit être adaptée pour que les herbes éventuelles ne viennent pas recouvrir le panneau solaire sur sa partie basse.



MONTAGE SUPPORT UNFIX 800 EGF (SUITE)

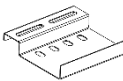
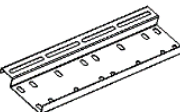

- Ajoutez les plaques d'extrémités pour ajuster la largeur en fonction de vos panneaux solaires. Ne serrez pas totalement les vis.

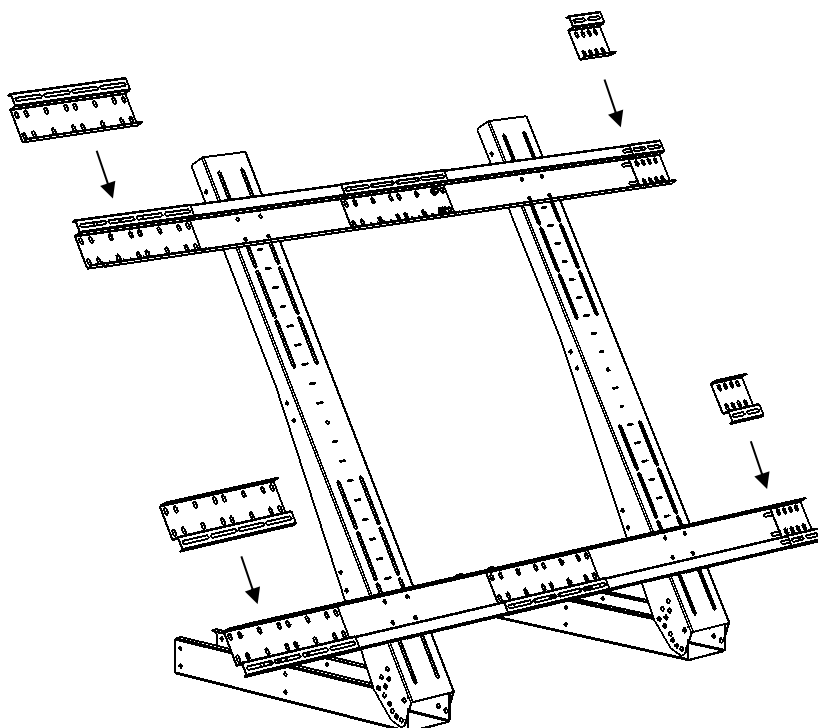
				
M8 X4	D8 X4	M8 X4	N°183 X2	N°170 X2





MONTAGE SUPPORT UNFIX 800 EGF (SUITE)

- Fixez les panneaux solaires. Si nécessaire, adaptez la longueur des cornières de fixation en fonction de la dimension de vos panneaux solaires.

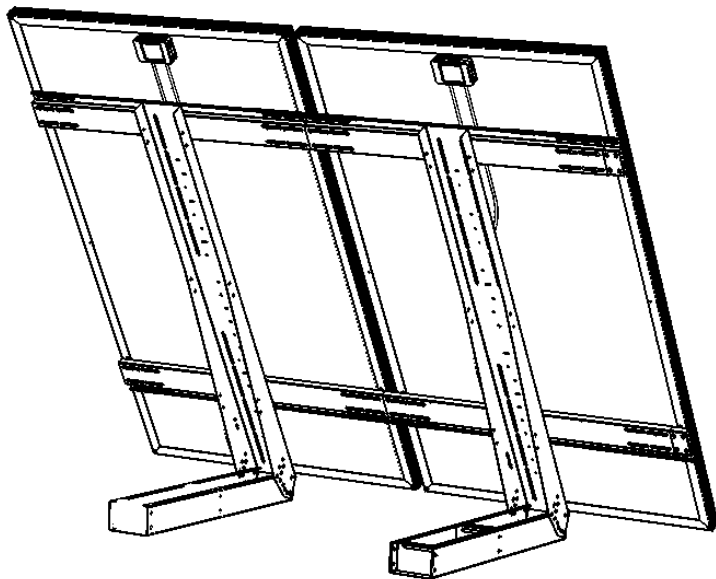
		
M8 X8	D8 X8	M8 X8





- Finissez la fixation du support grâce aux vis restantes.

		
M8 X36	D8 X36	M8 X36

MONTAGE CAISSE DE LESTAGE (EN OPTION)

- Montez la caisse de lestage avec les vis fournies. Réalisez un préserrage pour l'assemblage et réalisez le serrage complet quand la caisse est totalement assemblée.

		
M8 X8	D8 X8	M8 X8

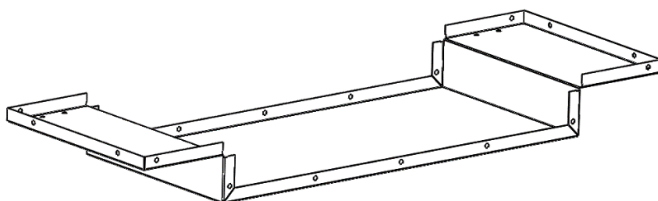

N°172
X1

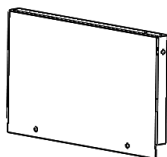

N°173
X2

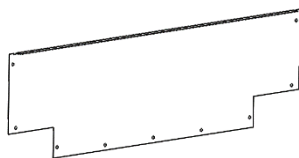
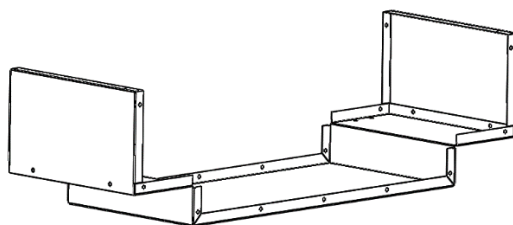

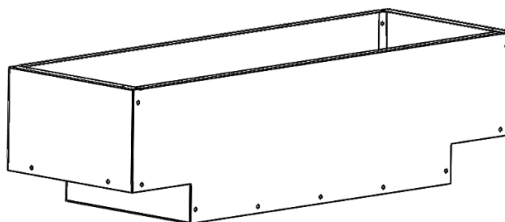

N°174
X2



MONTAGE CAISSE DE LESTAGE (EN OPTION)

- Positionnez la caisse de lestage sur les pieds du support UNIFIX 800 EGF et fixez-la .

		
M8 X8	D8 X8	M8 X8

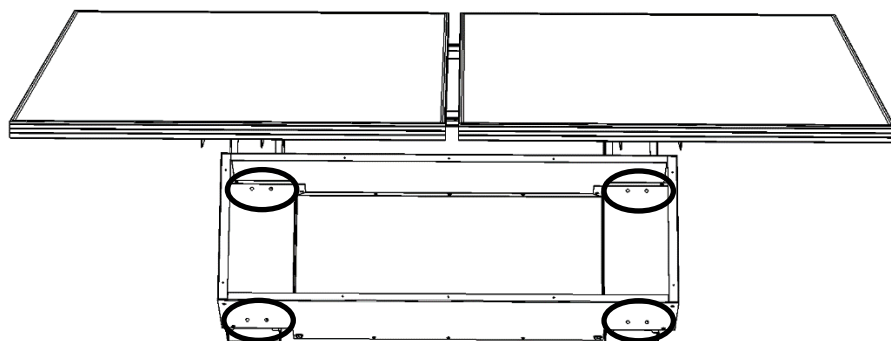
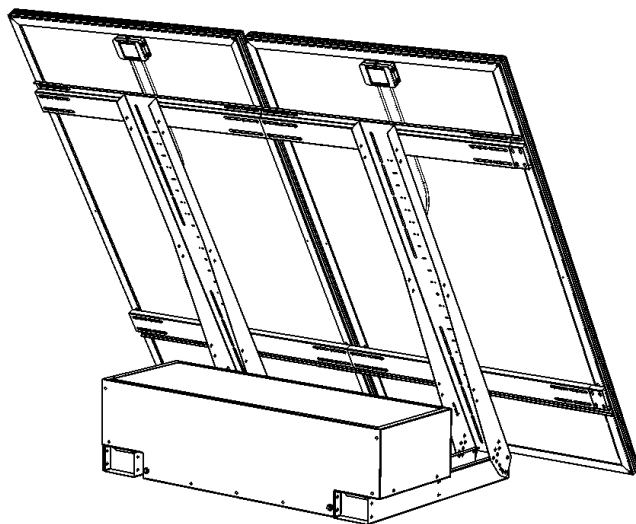

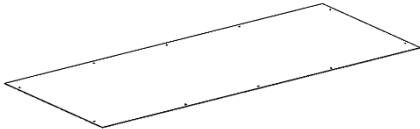

MONTAGE CAISSE DE LESTAGE (EN OPTION)

- Ajoutez le sable sec.

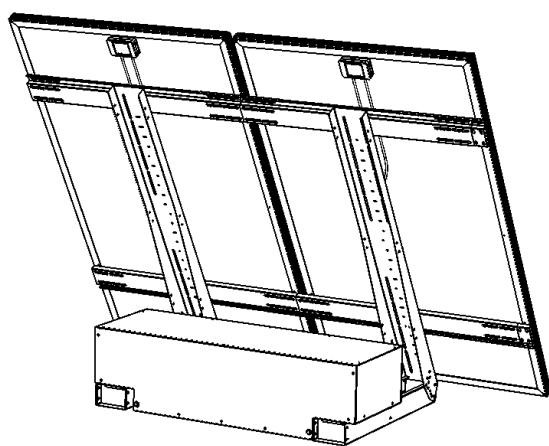
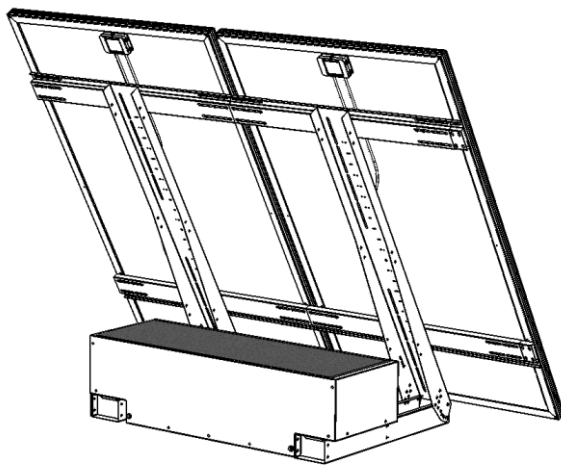
	
X10	N°175 X1



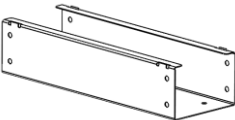
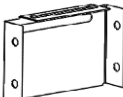

MONTAGE SUPPORT DALLE BETON (EN OPTION)

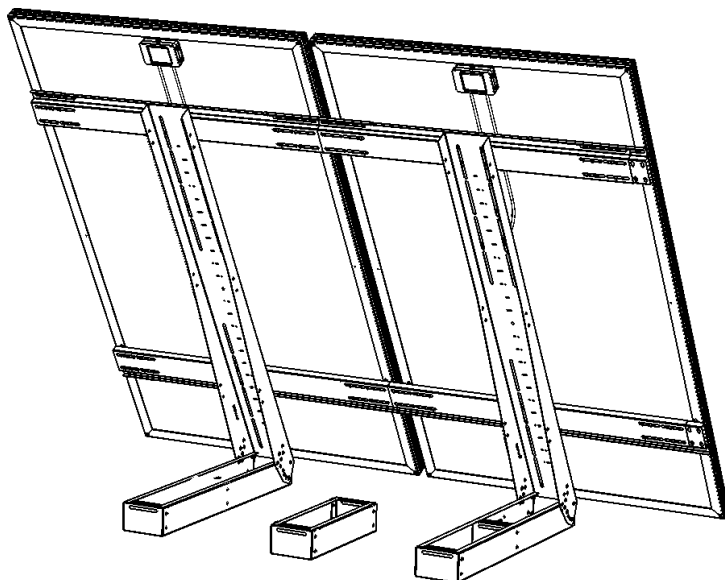
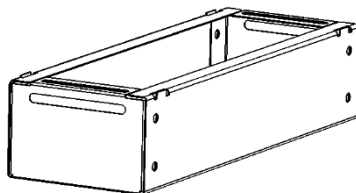
	M8x20 X8
	D8 X8
	M8 X8
	N°184 X1
	N°181 X2



MONTAGE SUPPORT DALLE BETON (EN OPTION)

- Fixez les 2 cornières qui supporteront les dalles de béton 40 x 40 cm.

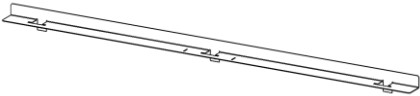
	M8x20 X6
	D8 X6
	M8 X6
	N°185 X2

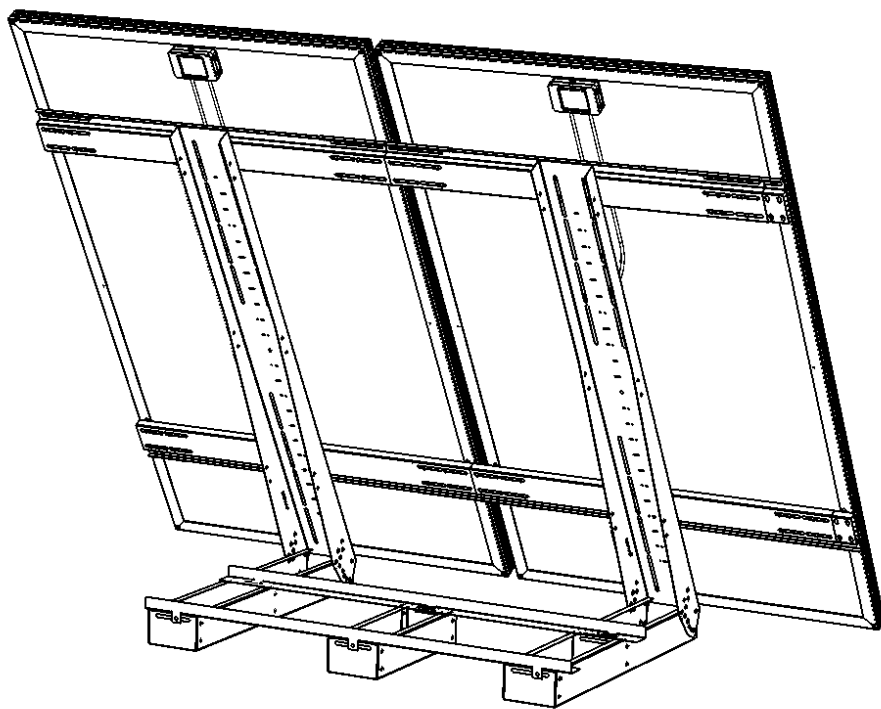

MONTAGE SUPPORT DALLE BETON (EN OPTION)

- Finalisez le lestage en ajoutant les plaques jusqu'à ce que le lestage soit suffisant.

RAPPEL : Respectez la limite maximale autorisée pour les dimensions et le poids des dalles (cf. p.3)

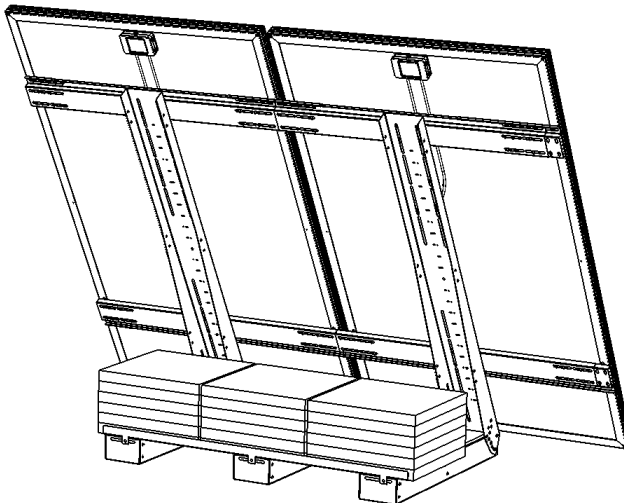
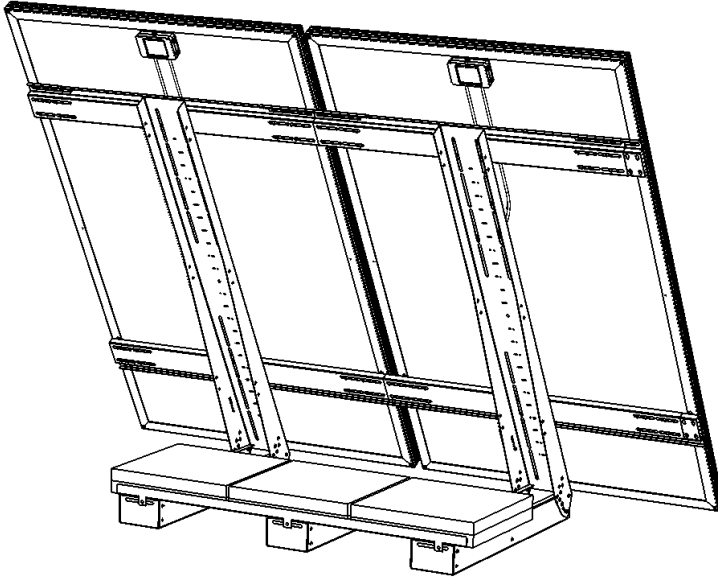

GARANTIE

La garantie couvre tout défaut ou vice de fabrication pendant 2 ans, à compter de la date d'achat (pièces et main d'œuvre).

La garantie ne couvre pas :

- l'usure normale des pièces
- les erreurs de montage

En cas de défauts, retournez le produit à votre distributeur, en y joignant :

- un justificatif d'achat daté (ticket de sortie de caisse, facture...)
- une note explicative du défaut.

Attention : notre SAV n'accepte pas les retours en port dû.

Après la garantie, notre SAV assure les réparations après acceptation d'un devis.

Contact SAV :

Uniteck- 1 Avenue de Rome

Zae Via Europa - bâtiment Cassis

34350 Vendres -France

France mail: sav@uniteck.fr

Fax: +33 (0)4 88 04 72 20

Dear customer, thank you for purchasing one of our Uniteck products. Please read all the instructions carefully and thoroughly before using the product.

DESCRIPTION

The Unifix 800 EGF Unifix brackets have been specially designed to fix your Unisun photovoltaic panels or equivalent (see compatible panels part)

Easy to install, Unifix 800 EGF can be fixed on a horizontal or flat surface (e.g. wall, concrete floor, wood frame) or can be weighted to the ground (e.g. turf)

They can be :

- fixed on a concrete floor thanks to its 8 m8-studs (not included)
- weighted using a ballast box for unifix 800 egf (option).
- weighted using the brackets for concrete slabs (option).

With their galvanized steel structure and corrosion-resistant stainless-steel screws, they are perfectly suited for outdoor use.

Equipped with a multi-position tilting system, Unifix brackets enable an optimization of your panel's performance depending on the chosen orientation :

- only unifix 800 egf : the adjustment angle is from 10 to 60 degrees.
- with ballast box option : the adjustment angle is from 30 to 60 degrees.
- with brackets for concrete slabs option : the adjustment angle is from 20 to 60 degrees

Thanks to its innovative design, UNIFIX 800 EGF brackets can be used to create a multi solar panels installation.



COMPATIBLE PANELS

With the design based on the use of Oblong drilling, Unifix allows the fixing of different panels of the market. Unifix 800 EGF accepts 1, 2 or 3 panels according to the references, with the spacing and dimensions of panels indicated below :

- width from 808 to 1100 mm
- length from 1200 o 1800 mm

BALLASTING WITH A BOX TO FILL OR WITH CONCRETE SLABS (OPTION)

The ballasting must be adapted to its environment of use (country, windy area,...) and its inclination. UNITECK cannot be responsible in case of an improper use.

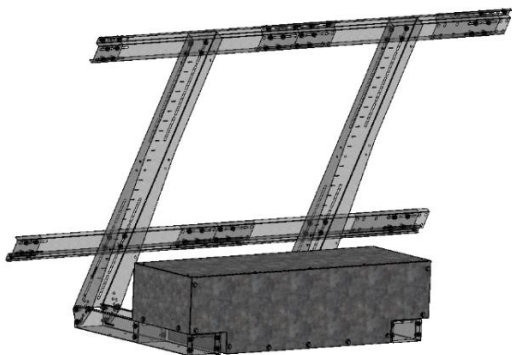

UNITECK ballast box is suitable for UNIFIX 800 EGF and for the ballasting of 2 solar panels, whose inclination angle is from 30 to 60 degrees. Its capacity is 130 litres, or 0,13 m³.

The ballast box is made to be filled with a 1800Kg/m³ dry sand, or 240 Kg.

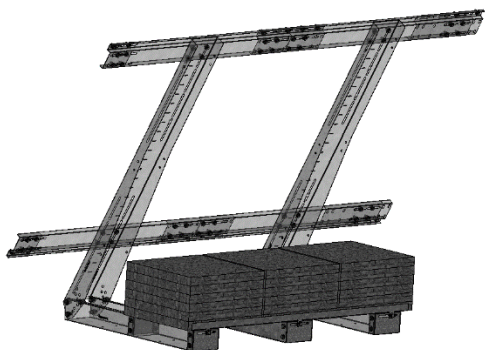

UNITECK concrete slabs brackets are made to carry 40 cm x 40 cm concrete slabs.

UNITECK concrete slabs brackets can carry until 24 standard concrete slabs weighing 12,5Kg, meaning a total ballast weight of 300Kg.

The inclination angle can vary from 20 to 60 degrees according to the number of slabs used.

RECOMMENDATIONS

- Mount Unifix brackets only on surfaces with a sufficient load carrying capacity.
- Take into account the additional weight with panel

Brackets	Panel
Unifix 800 EGF = 23 kg	2 x Unisun 300.12M = 2 x 18 kg

- Fastening : to prevent the accumulation of large quantities of snow behind the sensor, install appropriate barrier grids.
- The position of the solar panel influences your electrical production. Choose the most optimal inclination and orientation to suit your environment. Avoid shaded areas or objects that can be a source of shadow (eg tree)

SAFETY INSTRUCTIONS

- Take the appropriate measures to prevent accidents during your mounting steps.
- If the brackets and the mounting tools are exposed to sunlight for a long period, there is a risk of getting burnt. Make sure to protect yourself accordingly.
- When finished, check and make sure that all of your brackets and panels are fixed properly.



UNFIX 800 EGF MOUNTING

Recommended tightening torque

Nb. Mean coefficient of friction $\mu=0.20$ / Clamping at 50% of yield point

Screw	Torque
M 8	21,50 Nm
M 10	44,00 Nm

- Mount the legs

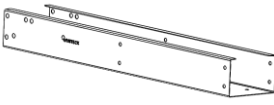
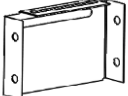
	M8x20 X16
	D8 X16
	M8 X16
	N°169 X2
	N°181 X4



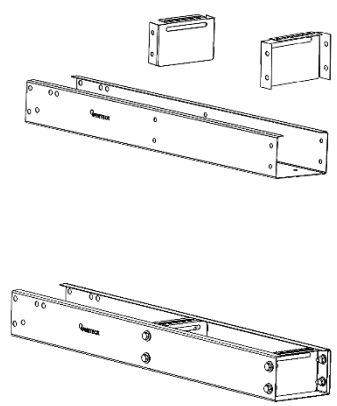

For a use with a ballast box

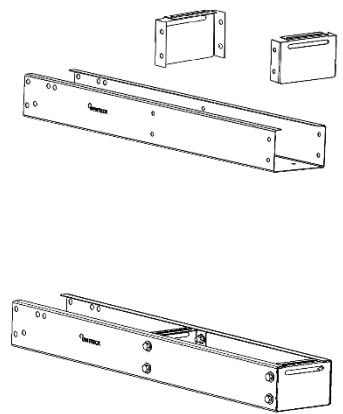

Other use



UNIFIX 800 EGF MOUNTING (CONTINUATION)

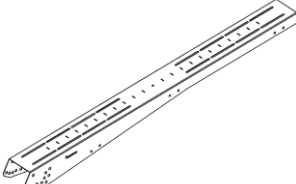

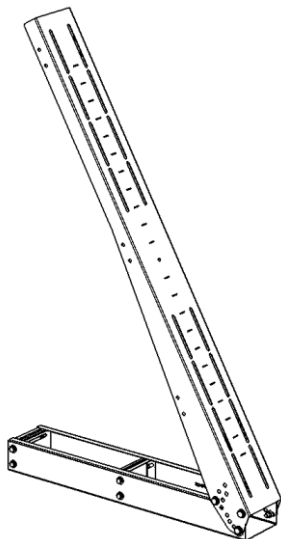

	M10x25 X12
	D10 X12
	M10 X12
	X2
	N°168 X2

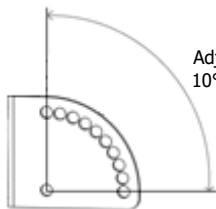

- Equipped with a multi-position tilting system, Unifix brackets allow for an optimization of your panel's performance depending on the chosen orientation.





Adjustable per
10° from 10 to
60°

Electrical performance according to inclination and panel orientation				
	0° 	30° 	60° 	90° 
Est	93%	90%	78%	55%
Sud-Est	93%	96%	88%	66%
Sud	93%	100%	91%	68%
Sud Ouest	93%	96%	88%	66%
Ouest	93%	90%	78%	55%

UNFIX 800 EGF MOUNTING (CONTINUATION)

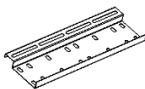
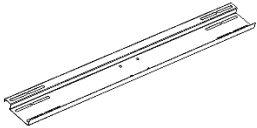

- Take pieces n°170 and 171, position them and pre-tighten the screws. The final tightening will be done at the end of the assembly.

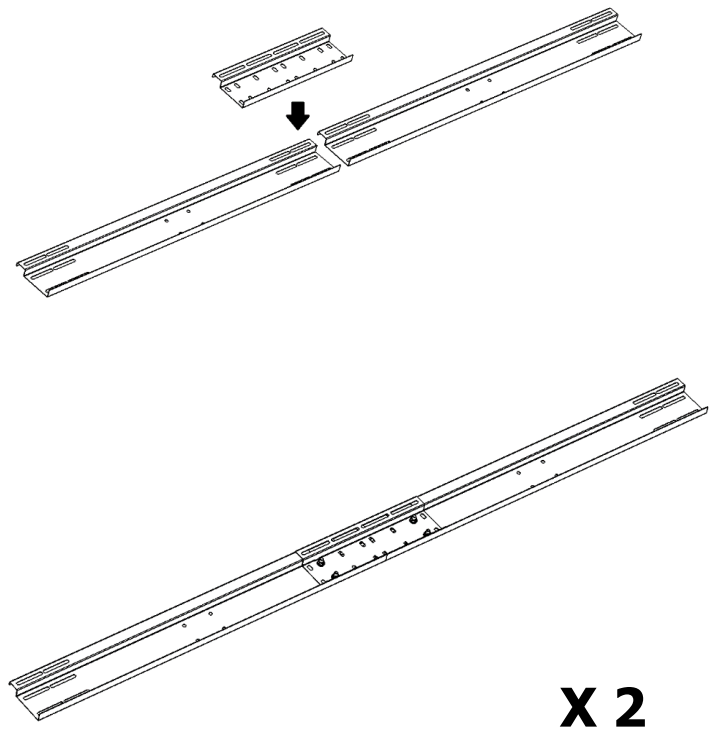
				
M8 X8	D8 X8	M8 X8	N°170 X2	N°174 X4



UNIFIX 800 EGF MOUNTING (CONTINUATION)

- Fix the rails previously prepared on the legs. Do not tighten them completely.

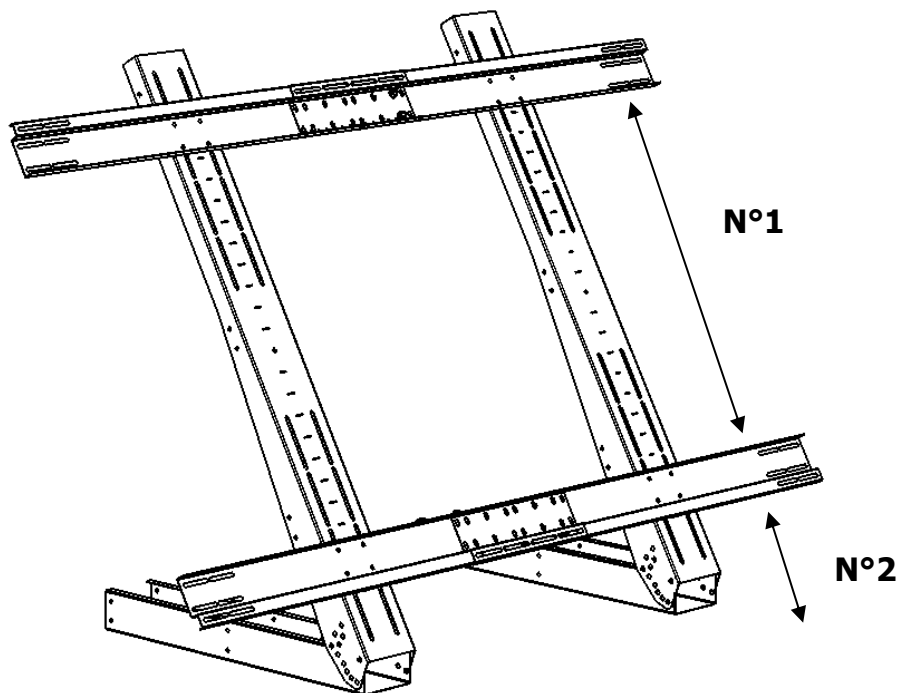

		
M8 X16	D8 X16	M8 X16

- Unifix 800 EGF brackets suit all types of panels.
- To adjust N°1 distance, first measure the distance between the central fixing axes of your panel.
- If you use UNIFIX 800 EGF brackets in a meadow or a lawn, distance N°2 must be adapted so that any plant cover the solar panel on its lower part.



UNFIX 800 EGF MOUNTING (CONTINUATION)

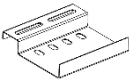
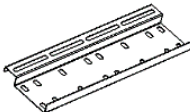

- Add the end plates to adjust the width according to your solar panels. Do not tighten the screws completely.

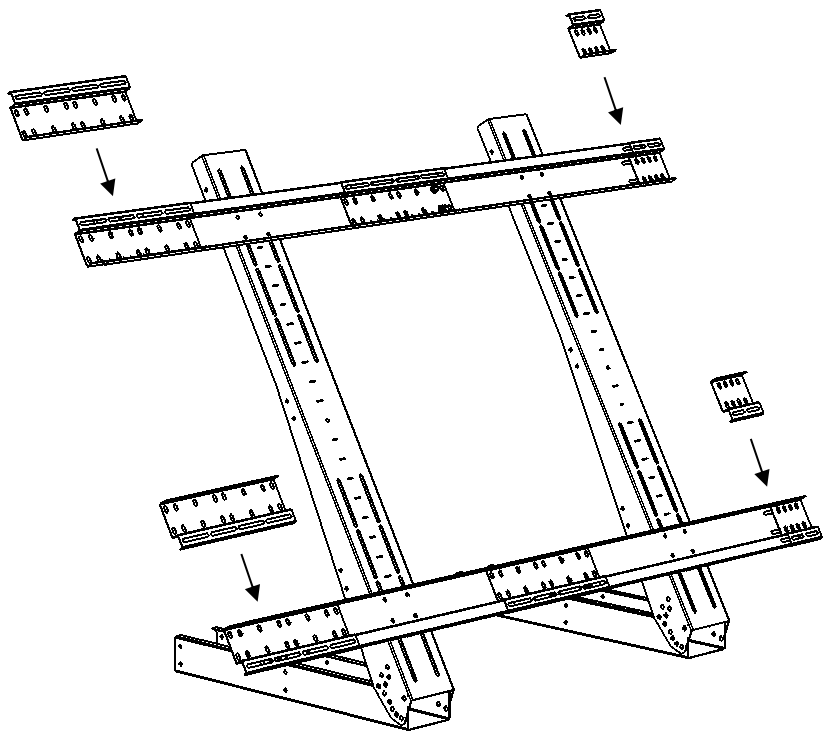
				
M8 X4	D8 X4	M8 X4	N°183 X2	N°170 X2





UNFIX 800 EGF MOUNTING (CONTINUATION)

- Fix the solar panels. If necessary, adapt the angle iron according to the solar panels size.

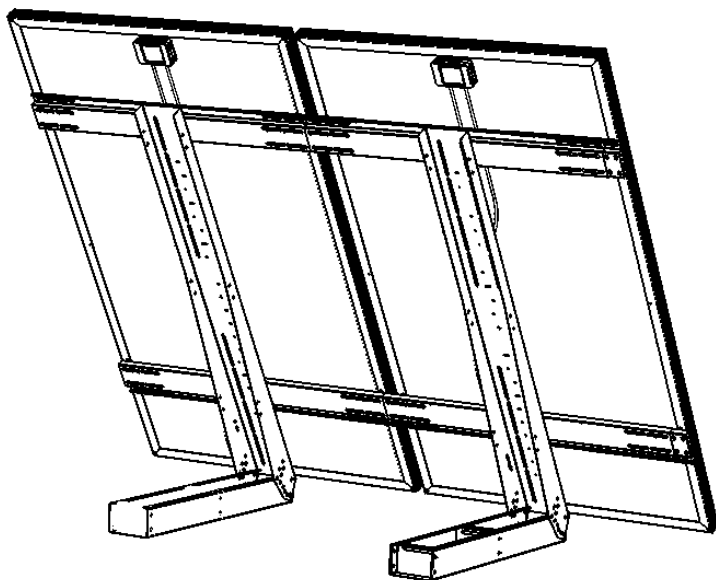
		
M8 X8	D8 X8	M8 X8





- Finish to fix the brackets with the remaining screws.

		
M8 X36	D8 X36	M8 X36

BALLAST BOX MOUNTING (OPTION)

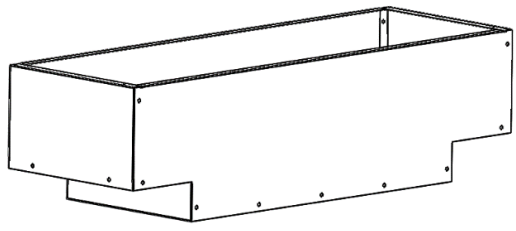
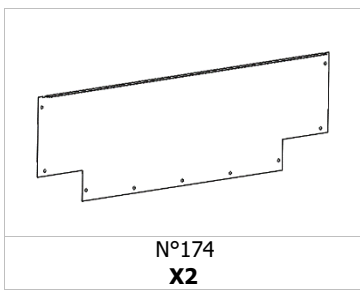
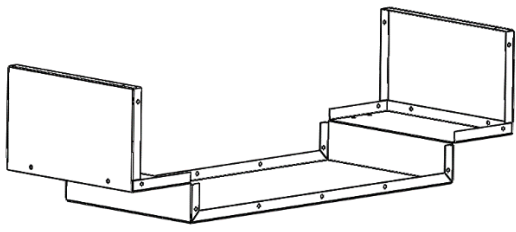
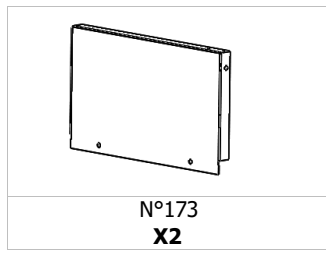
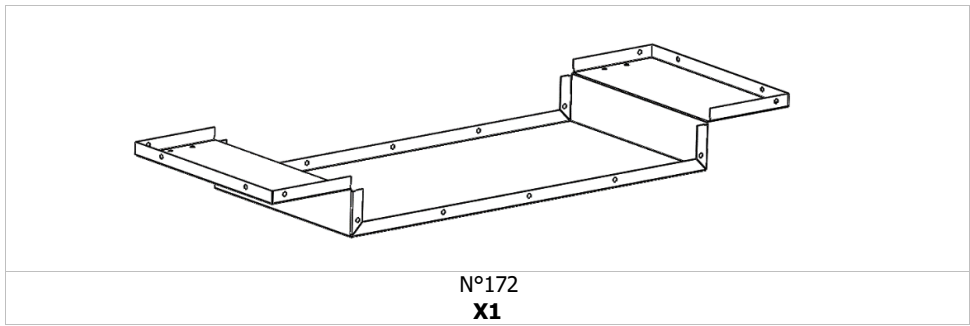

- Mount the ballast box with the provided screws. Pre-tighten them for assembly. The final tightening will be done at the end of the assembly.

		
M8 X8	D8 X8	M8 X8



BALLAST BOX MOUNTING (OPTION)

- Position the ballast box on UNIFIX 800 EGF brackets legs, and fasten it.

		
M8 X8	D8 X8	M8 X8

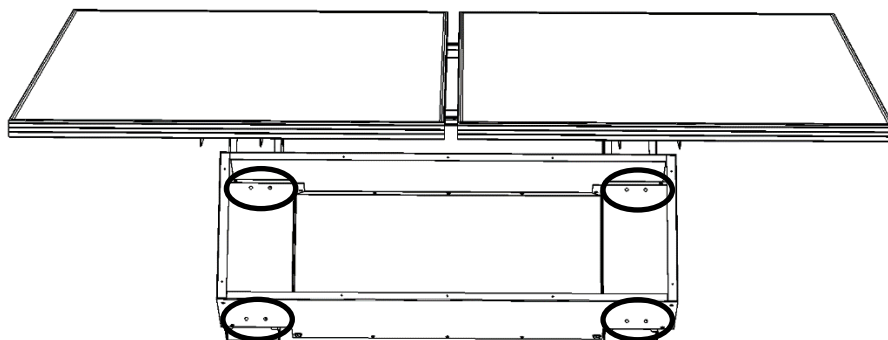
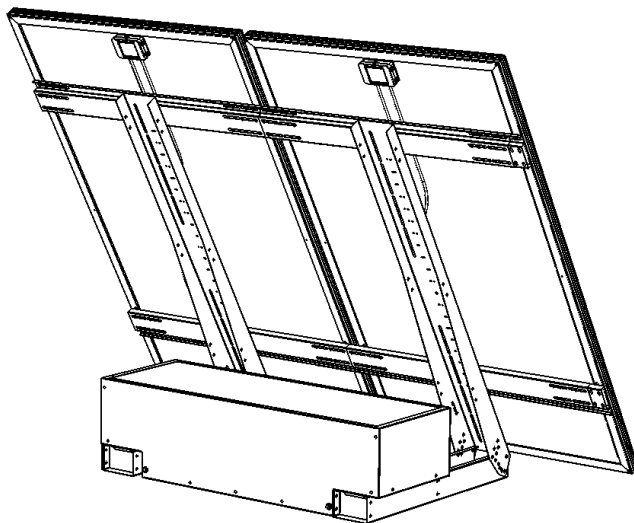

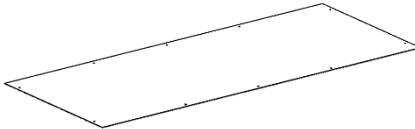

BALLAST BOX MOUNTING (OPTION)

- Add the dry sand.

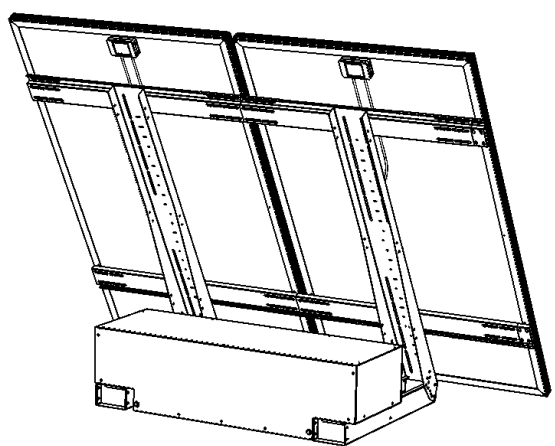
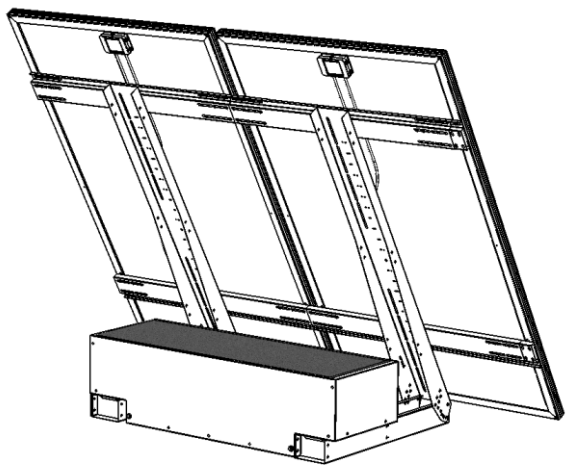
	
<p>X10</p>	<p>N°175 X1</p>



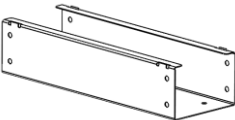
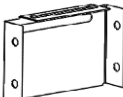

BRACKETS WITH CONCRETE SLABS MOUNTING (OPTION)

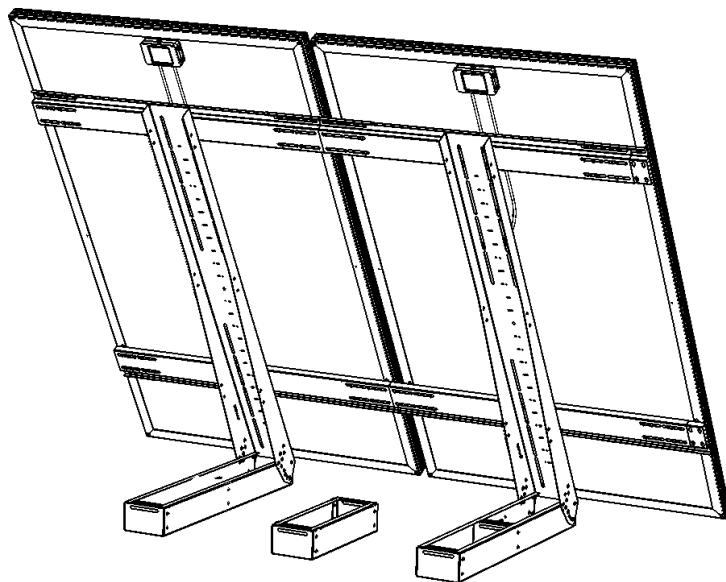
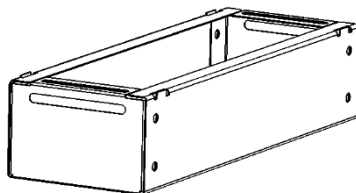
	M8x20 X8
	D8 X8
	M8 X8
	N°184 X1
	N°181 X2



BRACKETS WITH CONCRETE SLABS MOUNTING (OPTION)

- Fasten the 2 angle irons that will carry the 40 x 40 cm concrete slabs.

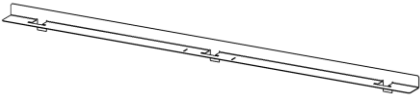
	M8x20 X6
	D8 X6
	M8 X6
	N°185 X2

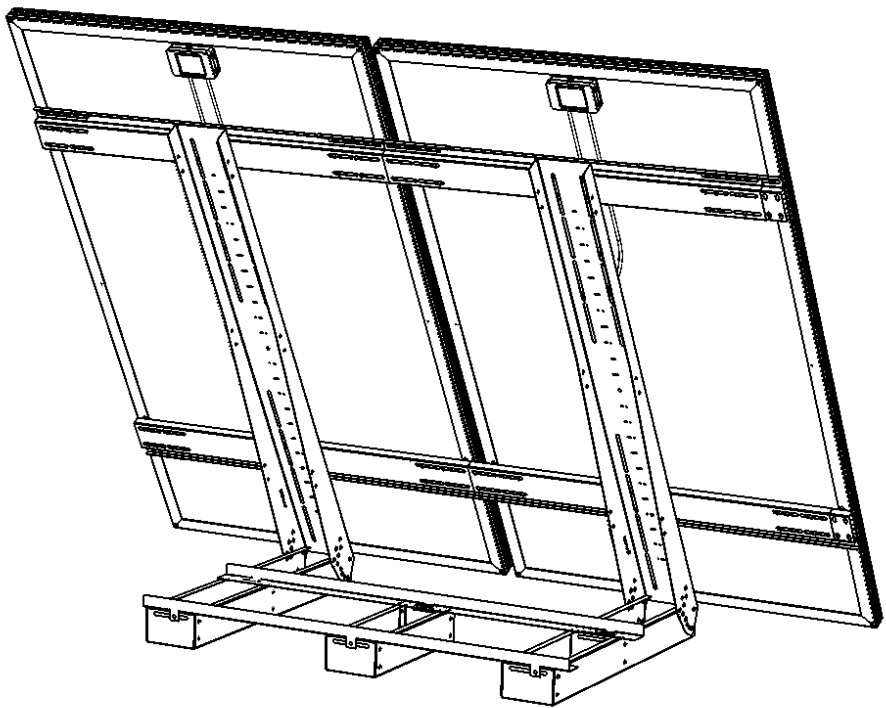

BRACKETS WITH CONCRETE SLABS MOUNTING (OPTION)

- Finalize the ballast adding concrete slabs until needed.

REMINDER : Respect the size of concrete slabs and the maximal weight allowed (cf. p.19)

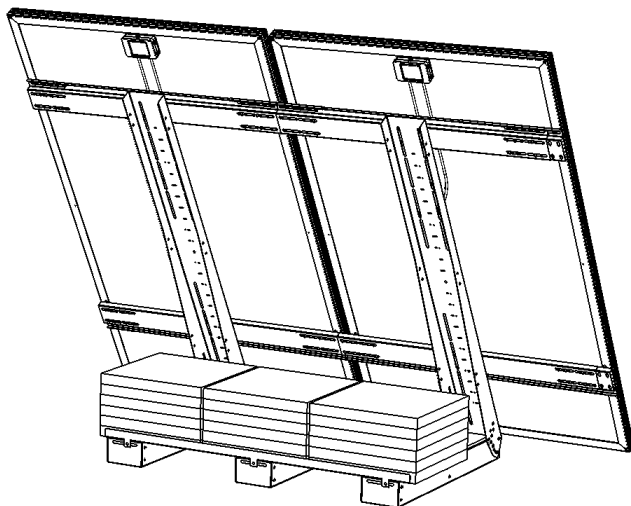
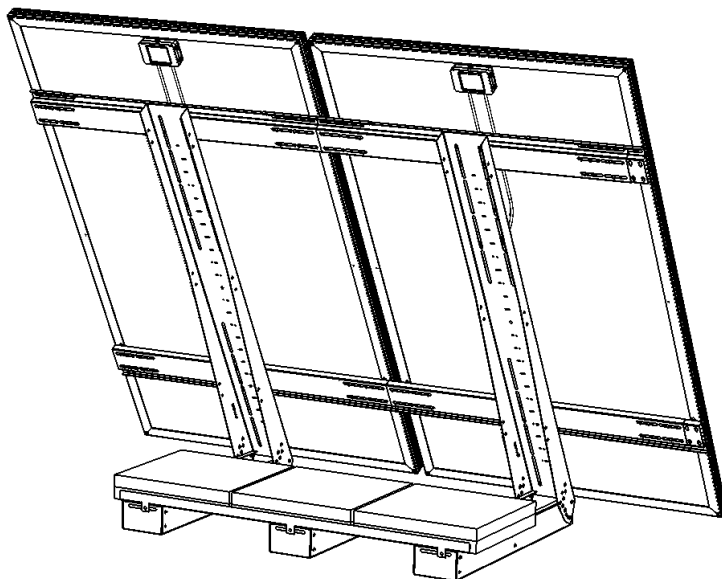

WARRANTY

The warranty covers any defect, manufacturing flaws for 1 year from the date of its purchase (Pieces and labour).

Warranty does not cover:

- normal wear of parts
- faulty mounting of bracket

In case of failure, return the product to your distributor by attaching:

- the dated proof of purchase (receipt, bill...)
- explanatory note of the failure

Caution: our after-sales service does not accept carriage forward/collected returns.

After the warranty, our after-sales service ensures repairs after acceptance of a quotation.

After-sales service contact :

Uniteck- 1 Avenue de Rome

Zae Via Europa - bâtiment Cassis

34350 Vendres -France

E-mail : sav@uniteck.fr

Fax : +33 (0)4 88 04 72 20

Estimado cliente, gracias por comprar nuestro producto Uniteck. Por favor lea con cuidado todas las instrucciones antes de usar el producto.

DESCRIPCIÓN

El soporte Unifix 800 EGF fue diseñado especialmente para fijar sus paneles solares Unisun o equivalentes (referirse a la parte « paneles compatibles »).

Fácil de instalar, Unifix 800 EGF se utiliza en una superficie plana, rígida y horizontal (ej : césped, arena, hormigón, marco de madera).

Se puede :

- fijar en un piso de hormigón gracias a sus 8 pernos m8 (no incluidos)
- lastrar utilizando la caja de lastre para unifix 800 egf (opción)
- lastrar utilizando el soporte para losas de hormigón (opción)

Gracias a su estructura de acero galvanizado y a sus tornillos resistentes a la corrosión, está perfectamente adaptado para un uso al aire libre.

Dotado de un sistema de inclinación con posiciones múltiples, el soporte Unifix permite optimizar su rendimiento según la orientación escogida :

- sólo : el ángulo de ajuste es de 10 a 60 grados.
- con opción caja de lastre : en ángulo de ajuste es de 30 a 60 grados.
- con el soporte de losa de hormigón : el ángulo de ajuste es de 20 a 60 grados.

Gracias a su diseño innovador, el soporte UNIFIX 800 EGF puede ser utilizado para realizar una instalación con varios paneles.



PANELES COMPATIBLES

Gracias a su diseño basado en una utilización de perforación oblonga, Unifix permite la fijación de varios paneles del mercado con fijación por tornillo M8.

Unifix 800 EGF acepta paneles de tamaño :

- anchura de 808 a 1100 mm
- longitud de 1200 a 1800 mm

LASTRE CON CAJA POR RELLENAR O CON LOSA DE HORMIGÓN (OPCIÓN)

El lastre debe ser adaptado a su entorno de utilización (país, viento, ...) y de inclinación. UNITECK no se hace responsable de un lastrado inadecuado.

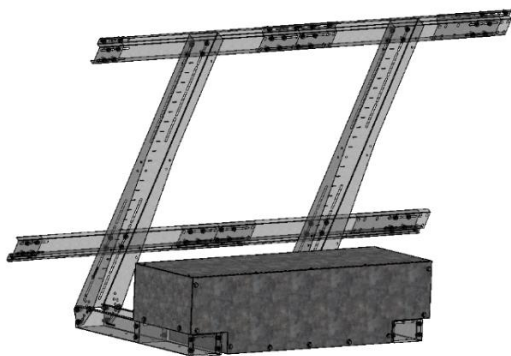

La caja de lastre UNITECK está diseñada para el soporte UNIFIX 800 EGF y para un lastre de 2 paneles cuyo ángulo de inclinación es de 30 a 60 grados. Tiene una capacidad de 130 litros o 0,13 m³.

La caja de lastre está diseñada para contener arena seca con densidad de 1800kg/ m³, o sea un total de 240 kg.

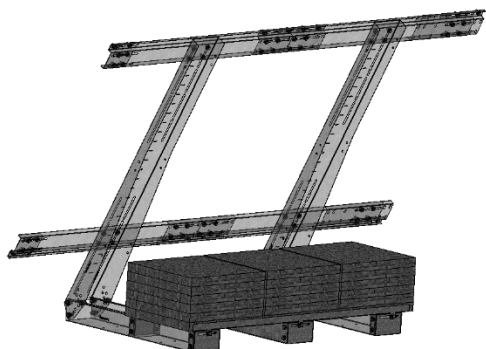

El soporte Losa de hormigón UNITECK está diseñado para soportar losas de hormigón de 40 cm x 40 cm.

El soporte Losa de hormigón UNITECK puede soportar hasta 24 losas estándar de un peso de 12,5Kg, o sea un peso total de lastre de 300 Kg.

El ángulo de inclinación puede variar de 20 a 60 grados según la cantidad de losas utilizadas.

RECOMENDACIONES

- Montar el soporte Unifix únicamente en superficies con capacidad de carga suficiente. Tome en cuenta la carga adicional con panel :

Soporte	Panel
Unifix 800 EGF = 23 kg	2 x Unisun 300.12M = 2 x 18 kg

- Para evitar que se acumulen grandes cantidades de nieve detrás del captor, instale previamente unas rejillas adecuadas.
- La disposición de los captores influye en el rendimiento eléctrico. escoja la inclinación y la orientación las más óptimas dependiendo de su entorno. Evite las zonas de sombra, o que algunos objetos sean fuente de sombra (ej. árbol)

CONSIGNAS DE SEGURIDAD

- Tome las medidas adecuadas para prevenir los accidentes durante sus fases de montaje.
- La exposición del soporte y del material de montaje a los rayos del sol durante un largo tiempo puede provocar quemaduras. Protéjase.
- Cuando acabe su montaje, asegúrese de que sus soportes y paneles estén bien fijados.



MONTAJE SOPORTE UNFIX 800 EGF

Par de apriete recomendado

Coficiente de fricción promedio $\mu=0,20$ / Apriete al 50% del límite elástico

Tornillo	Apriete
M 8	21,50 Nm
M 10	44,00 Nm

- Realice el montaje de las patas.

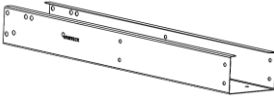
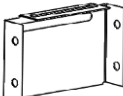
	M8x20 X16
	D8 X16
	M8 X16
	Nº169 X2
	Nº181 X4



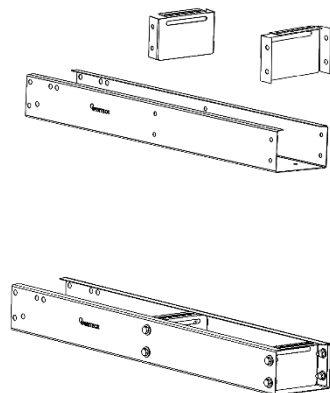

Para la utilización de una caja de lastre

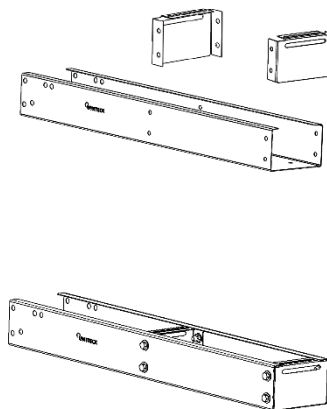

Para otra utilización





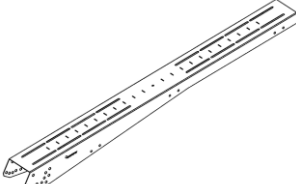

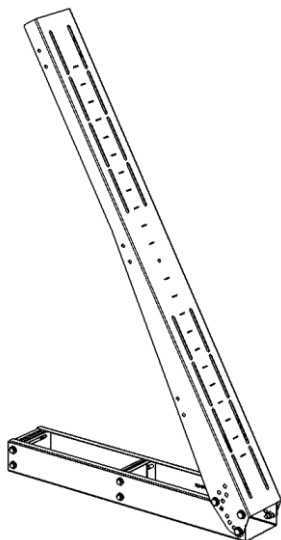
MONTAJE SOPORTE UNIFIX 800 EGF (CONTINUACIÓN)

	M10x25 X12
	D10 X12
	M10 X12
	X2
	N°168 X2

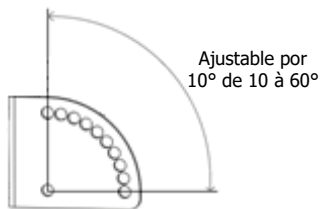



- UNIFIX tiene un sistema de inclinación con posiciones múltiples. Defina la inclinación deseada según la orientación elegida.



Rendimiento eléctrico según la inclinación y la orientación del panel				
	0° 	30° 	60° 	90° 
Este	93%	90%	78%	55%
Sudeste	93%	96%	88%	66%
Sur	93%	100%	91%	68%
Sudoeste	93%	96%	88%	66%
Oeste	93%	90%	78%	55%

MONTAJE SOPORTE UNFIX 800 EGF (CONTINUACIÓN)

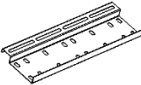
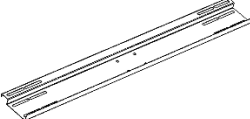

- Tome las piezas N°170 y 171. Colóquelas y realice un apriete previo de los tornillos. La fijación definitiva se hará más tarde.

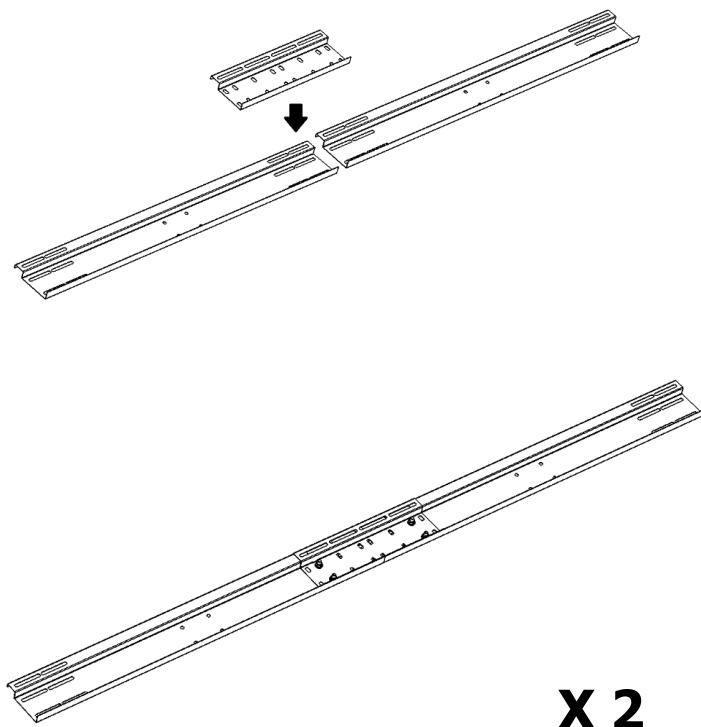
				
M8 X8	D8 X8	M8 X8	N°170 X2	N°174 X4



MONTAJE SOPORTE UNIFIX 800 EGF (CONTINUACIÓN)

- Fije los travesaños previamente preparados en las patas. No los apriete totalmente.

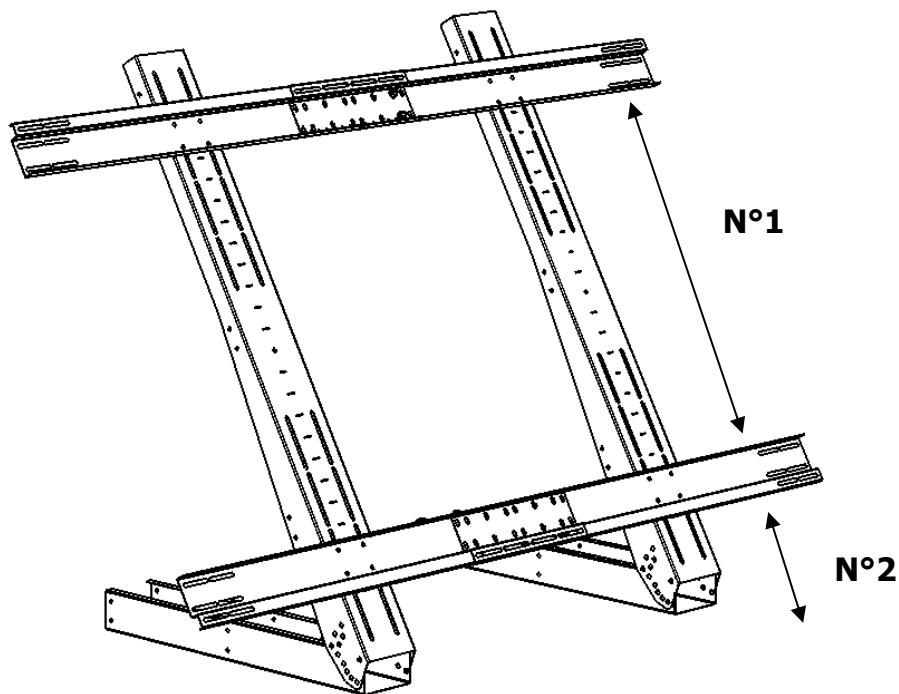

		
M8 X16	D8 X16	M8 X16

- El soporte UNIFIX 800 EGF se adapta a todos los tipos de paneles.
- Para ajustar la distancia **Nº1**, mida previamente la distancia entre los ejes de fijación de su panel.
- Si utiliza su soporte UNIFIX 800 EGF en una superficie con césped o plantas, debe adaptar la distancia **Nº2** para que ninguna planta eventual cubra el panel solar en su parte inferior.



MONTAJE SOPORTE UNIFIX 800 EGF (CONTINUACIÓN)

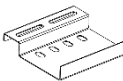
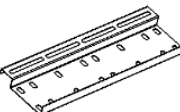

- Agregue las placas en las extremidades para ajustar la anchura según la de sus paneles solares. No apriete totalmente los tornillos.

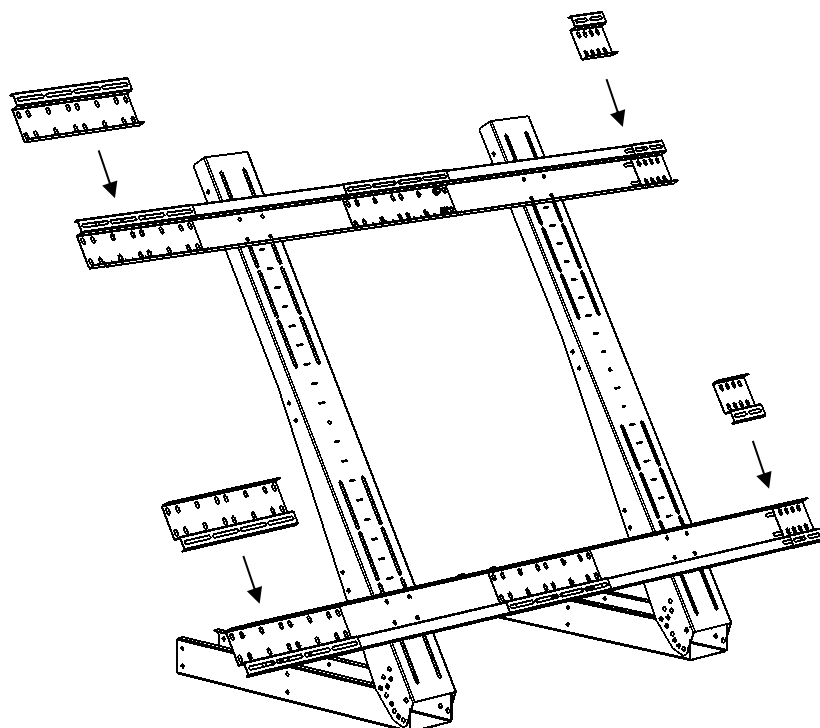
				
M8 X4	D8 X4	M8 X4	N°183 X2	N°170 X2





MONTAJE SOPORTE UNFIX 800 EGF (CONTINUACIÓN)

- Fije los paneles solares. Si lo necesita, ajuste la longitud de los ángulos de fijación al tamaño de los paneles solares.

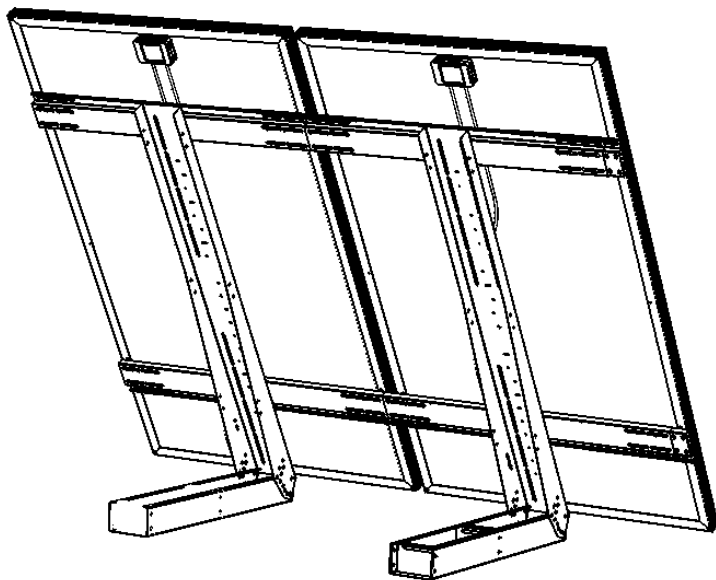
		
M8 X8	D8 X8	M8 X8





- Acabe de fijar el soporte con los tornillos restantes.

		
M8 X36	D8 X36	M8 X36

MONTAJE CAJA DE LASTRE (OPCIÓN)

- Monte la caja de lastre con los tornillos provistos. Realice un pre-apriete para el montaje, y el apriete definitivo cuando la caja esté totalmente ensamblada.

		
M8 X8	D8 X8	M8 X8

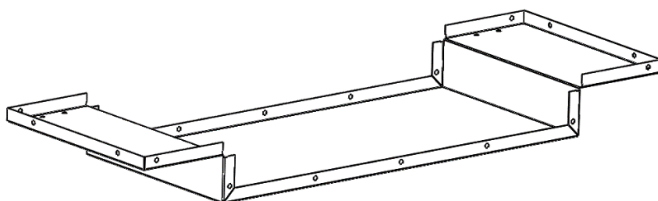

N°172
X1

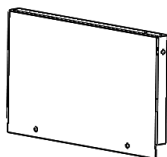

N°173
X2

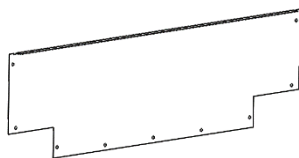
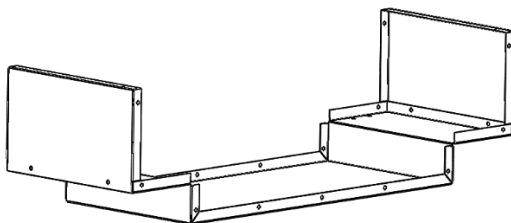

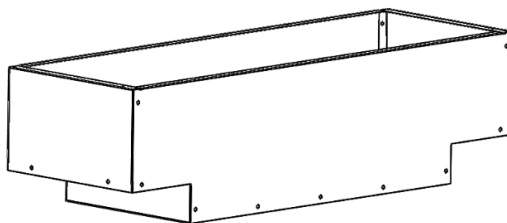

N°174
X2



MONTAJE CAJA DE LASTRE (OPCIÓN)

- Coloque la caja de lastre en las patas del soporte UNIFIX 800 EGF y fíjela.

		
M8 X8	D8 X8	M8 X8

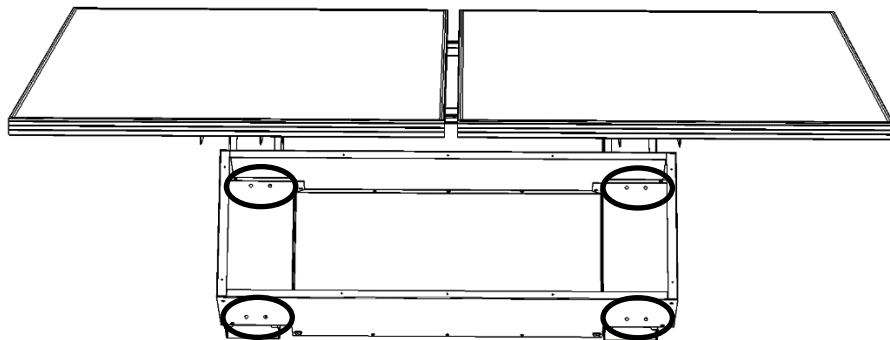
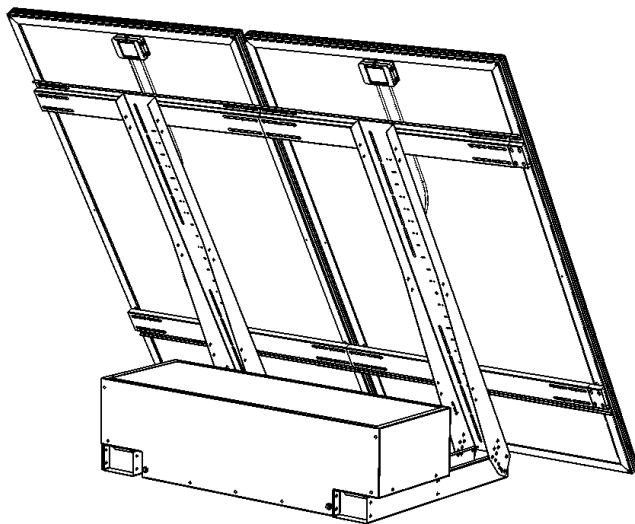

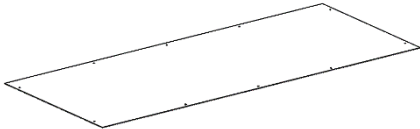

MONTAJE CAJA DE LASTRE (OPCIÓN)

- Agregue la arena seca.

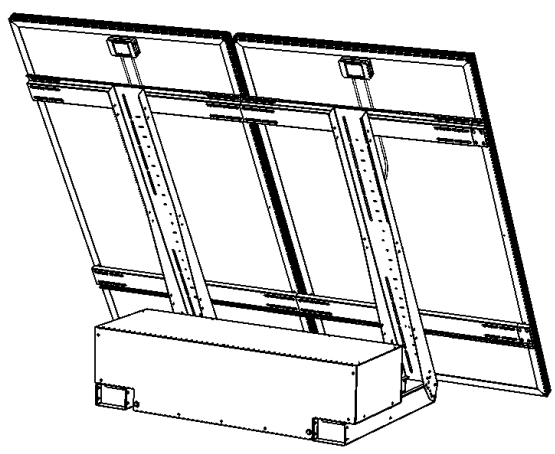
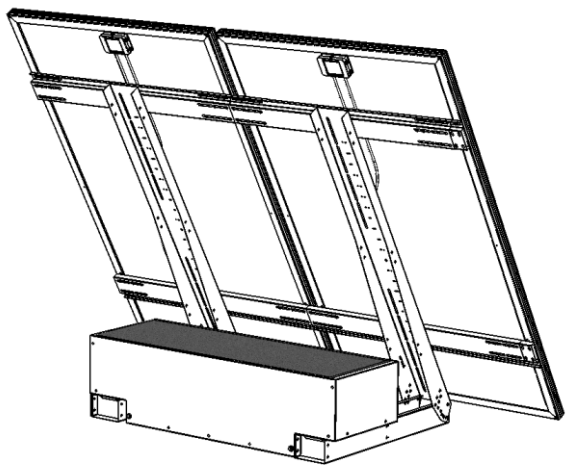
	
X10	Nº175 X1



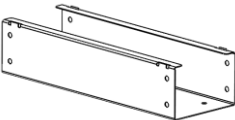
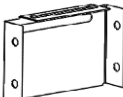

MONTAJE SOPORTE LOSA DE HORMIGÓN (OPCIÓN)

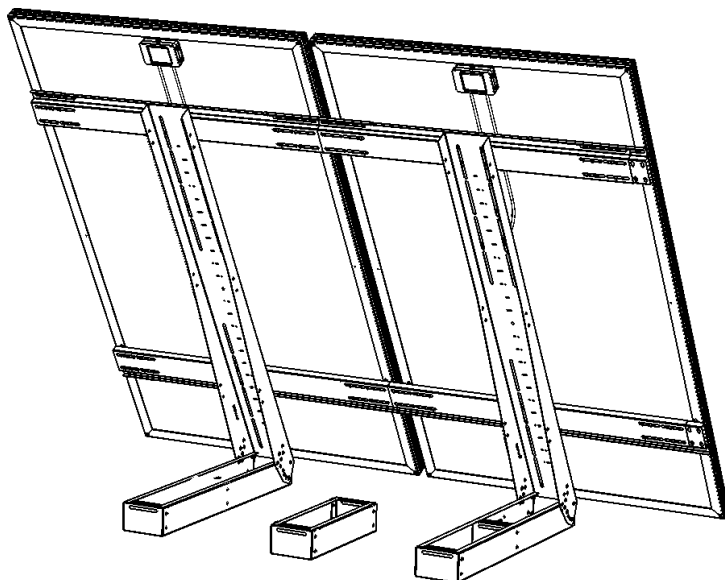
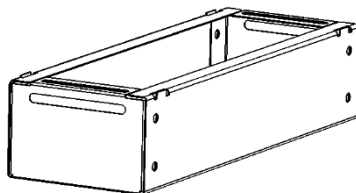
	M8x20 X8
	D8 X8
	M8 X8
	N°184 X1
	N°181 X2



MONTAJE SOPORTE LOSA DE HORMIGÓN (OPCIÓN)

- Fije los 2 ángulos que soportarán las losas de hormigón 40 x 40 cm.

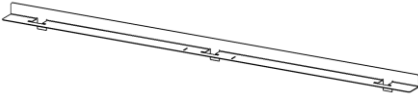
	M8x20 X6
	D8 X6
	M8 X6
	N°185 X2

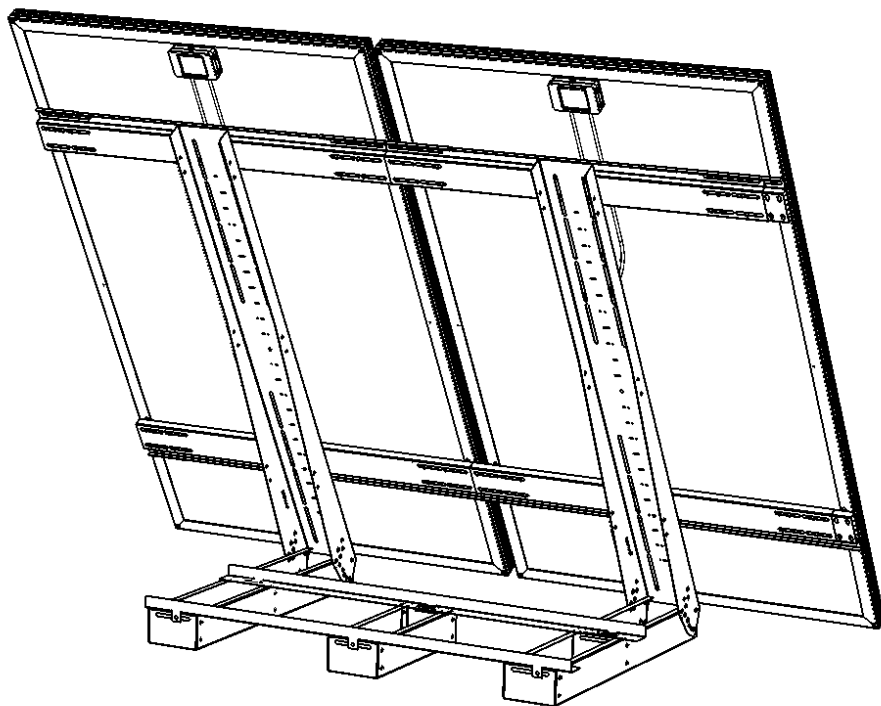

MONTAJE SOPORTE LOSA DE HORMIGÓN (OPCIÓN)

- Finalice el lastre agregando las placas hasta que sea suficiente.

RECORDATORIO : Respete el límite máximo autorizado en cuanto al tamaño y al peso de las losas (cf. p.35)

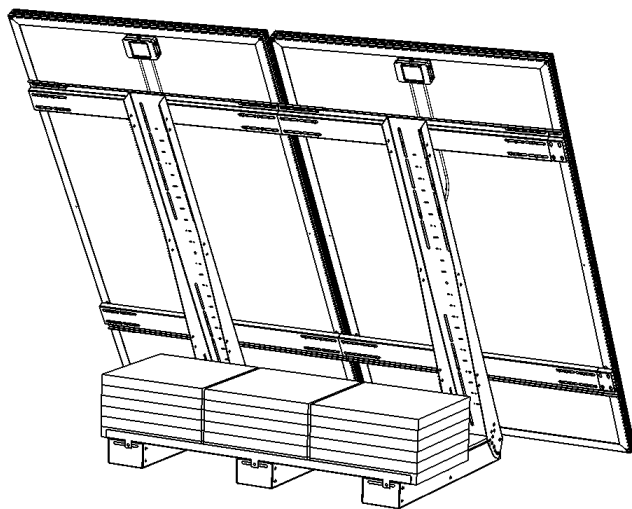
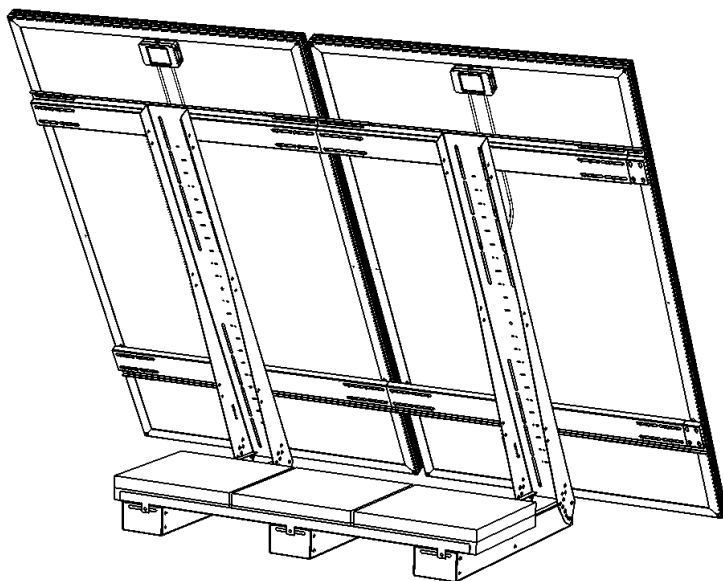

GARANTÍA

La garantía cubre todo defecto de fabricación durante 2 años después de la fecha de compra (piezas y mano de obra).

La garantía no cubre :

- el desgaste normal de las piezas
- los errores de montaje

Si encuentra algún defecto, devuelva el producto a su distribuidor, junto con :

- un comprobante de compra fechado (boleto de compra, factura...)
- una nota explicativa sobre el defecto encontrado

Cuidado : nuestro servicio postventa no acepta devoluciones en franqueo debido.

Después de la garantía, nuestro servicio postventa realiza las reparaciones después de aceptación de una cotización.

Contacto Servicio Postventa :

Uniteck- 1 Avenue de Rome

Zae Via Europa - bâtiment Cassis

34350 Vendres - France

E-mail: sav@uniteck.fr

Fax: +33 (0)4 88 04 72 20